



GP 310 / 300 MOTORCYCLE CALIPERS

Caliper Highlights:

Wilwood's **GP 310** and **GP 300** motorcycle disc brake calipers have been designed and engineered for use on 1984 - 2005 Harley-Davidson® Motorcycles. Built around a 4-piston, high performance powerhouse, these billet aluminum calipers bring distinctive, bolt-on styling: Direct leg-mounted calipers are available for all single and dual disc models (except Springer and 4-speed FL models), as well as the 1983 XR 1000.

-  Polished
-  Chrome

Rear calipers are available for all Softail®, Dyna, and touring models, utilizing unique bracket designs that combine the right elements of strength and style.

The **GP 310** and **GP 300** calipers are available in polished or brilliant chrome finishes, with the added performance characteristics found in Wilwood's racing calipers: stainless steel pistons to reduce brake fade while resisting corrosion and high temperature piston seals for extended life, controlled retraction and drag free operation. Additional features include bright-finish bleed screws and hardware, exclusive pad anti-rattle clip, and brake pads designed to operate in the widest range of temperatures and environments, utilizing our industry leading stainless steel rotor compatible formulation.

GP 310 FRONT MOTORCYCLE CALIPER ORDERING INFORMATION:

DESCRIPTION		POLISHED	CHROME
Front Left Hand Caliper (single)	1984-1999	120-7737-P	120-7737
Front Right Hand Caliper	1984-1999	120-7736-P	120-7736
Optional Mounting Bolt Kit, P/N: 230-4237			
Front Left Hand Caliper (single)	2000-Present	120-7739-P	120-7739
Front Right Hand Caliper	2000-Present	120-7738-P	120-7738
Optional Mounting Bolt Kit, P/N: 230-6330			



GP 310 REAR MOTORCYCLE CALIPER ORDERING INFORMATION:

DESCRIPTION (Bracket Not Included)		POLISHED	CHROME
Rear Right Hand Caliper (Std 3.50" Mount)		120-7740-P	120-7740
Rear Left Hand Caliper (Std 3.50" Mount) (1)		120-7741-P	120-7741
Optional Mounting Bolt Kit, P/N: 230-4236			
NOTE: (1) USE WITH DYNA "BOTTOM" BRACKET			



GP 310 REAR MOTORCYCLE CALIPER BRACKETS ORDERING INFORMATION:

GP 310 REAR BRACKET DESCRIPTION		POLISHED	CHROME
Softail® Bracket Kit	1984-1999	250-8035-P	250-8035
Softail® Bracket Kit	2000-Present	250-8036-P	250-8036
Dyna Bracket Kit	1984-1999	250-8034-P	250-8034
Dyna Bracket Kit	2000-Present	250-8033-P	250-8033
Dyna "Bottom" Bracket Kit (1)	1984-1999	250-8252-P	250-8252
Cruiser Bracket Kit	1984-1999	Call for availability	
Cruiser Bracket Kit	2000-Present	Call for availability	
Optional Mounting Bolt Kit, P/N: 230-4236 is included with brackets			
NOTE: (1) LOCATES CALIPER ON THE BOTTOM SIDE OF THE ROTOR USE WITH LEFT HAND GP 310 REAR CALIPER			

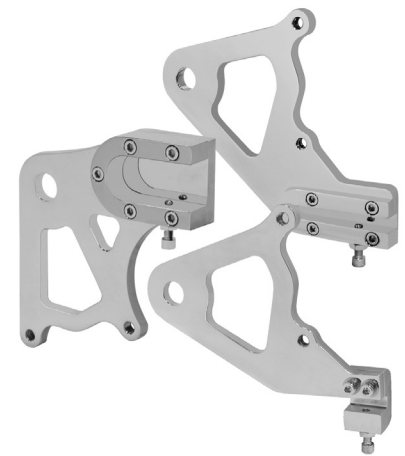



GP 310 FRONT, GP 300 FRONT / REAR MOTORCYCLE CALIPER, MOUNTING DIMENSIONS:

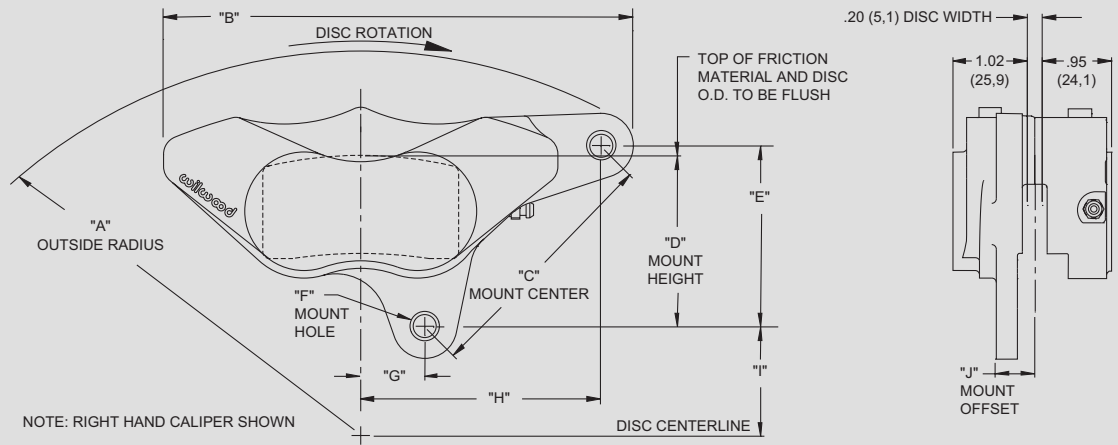

NOTE: RIGHT HAND CALIPER SHOWN

DIMENSIONS CORRECT WHEN USED WITH A 11.5 (292,1) DIA x .20 (5,1) DISC. OTHER MOUNTING DIMENSIONS AVAILABLE

CALIPER	"A"	"B"	"C"	"D"	"E"	"F"	"G"	"H"	"I"	"J"
GP 300 (1984-99)	7.21 (183,1)	6.48 (164,1)	3.44 (87,4)	2.33 (59,2)	2.46 (62,5)	3/8-16 THD	.87 (22,1)	3.27 (83,1)	3.43 (86,7)	.53 (13,5)
GP 310 (1984-99)	7.17 (182,1)	6.39 (162,3)	3.44 (87,4)	2.33 (59,2)	2.46 (62,5)	3/8-16 THD	.87 (22,1)	3.27 (83,1)	3.42 (86,7)	.53 (13,5)
GP 310 (2000-UP)	6.83 (173,5)	6.28 (159,5)	2.72 (69,1)	2.18 (55,4)	1.99 (50,5)	M10 x 1.5	1.31 (33,3)	3.16 (80,3)	3.57 (90,7)	.78 (19,8)

GP 310 REAR MOTORCYCLE CALIPER, MOUNTING DIMENSIONS:

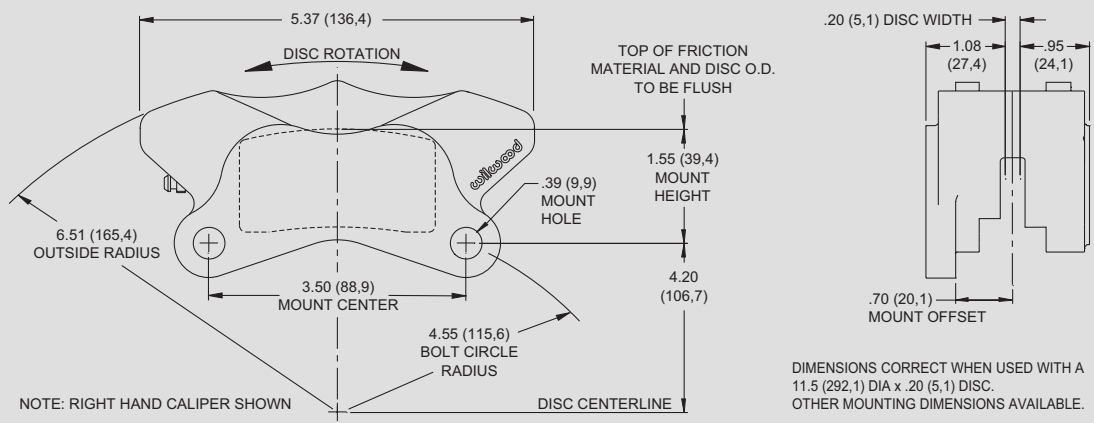

NOTE: RIGHT HAND CALIPER SHOWN

DIMENSIONS CORRECT WHEN USED WITH A 11.5 (292,1) DIA x .20 (5,1) DISC. OTHER MOUNTING DIMENSIONS AVAILABLE.

GP 300 MOTORCYCLE CALIPER ORDERING INFORMATION:

DESCRIPTION		POLISHED	CHROME	BLACK
Front Left Hand Caliper (single)	1984-1999	120-3933-P	120-4243	
Front Right Hand Caliper	1984-1999	120-3945-P	120-4242	
Optional Mounting Bolt Kit, P/N: 230-4237				
Rear Caliper (bracket not included)		120-3935-P	120-4244	
Rear Softail® Bracket Kit (shown with caliper lower right)	1984-1999			250-4235



SERVICE PARTS ORDERING INFORMATION:

DESCRIPTION	PART NUMBER
GP 300 and GP 310 Brake Pads (caliper set)	150-8733-2
GP 300 and GP 310 Seal Kit	130-3602

NOTES: HARLEY-DAVIDSON® MOTORCYCLES SPECIFIES USE OF DOT 5 SILICONE BRAKE FLUID BECAUSE OF ITS MINIMIZED IMPACT ON PAINTED SURFACES. WILWOOD DISC BRAKE CALIPERS WILL WORK WITH EITHER FLUID, BUT NEVER MIX DOT 5 SILICONE BRAKE FLUID WITH DOT 3, 4, OR 5.1 FLUIDS.

Brakes are critical safety components, see warnings and disclaimer on page 131